

37942A

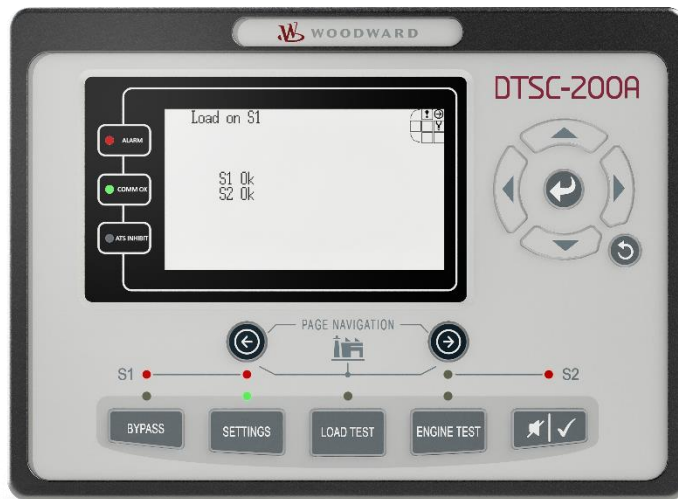

DTSC-200A ATS Controller - Application



Application

Release 1.0 - 0

**WARNING**

Read this entire manual and all other publications pertaining to the work to be performed before installing, operating, or servicing this equipment. Practice all plant and safety instructions and precautions. Failure to follow instructions can cause personal injury and/or property damage.

The engine, turbine, or other type of prime mover should be equipped with an overspeed (overtemperature, or overpressure, where applicable) shutdown device(s), that operates totally independently of the prime mover control device(s) to protect against runaway or damage to the engine, turbine, or other type of prime mover with possible personal injury or loss of life should the mechanical-hydraulic governor(s) or electric control(s), the actuator(s), fuel control(s), the driving mechanism(s), the linkage(s), or the controlled device(s) fail.

Any unauthorized modifications to or use of this equipment outside its specified mechanical, electrical, or other operating limits may cause personal injury and/or property damage, including damage to the equipment. Any such unauthorized modifications: (i) constitute "misuse" and/or "negligence" within the meaning of the product warranty thereby excluding warranty coverage for any resulting damage, and (ii) invalidate product certifications or listings.

**CAUTION**

To prevent damage to a control system that uses an alternator or battery-charging device, make sure the charging device is turned off before disconnecting the battery from the system.

Electronic controls contain static-sensitive parts. Observe the following precautions to prevent damage to these parts.

- Discharge body static before handling the control (with power to the control turned off, contact a grounded surface and maintain contact while handling the control).
- Avoid all plastic, vinyl, and Styrofoam (except antistatic versions) around printed circuit boards.
- Do not touch the components or conductors on a printed circuit board with your hands or with conductive devices.

**OUT-OF-DATE PUBLICATION**

This publication may have been revised or updated since this copy was produced. To verify that you have the latest revision, be sure to check the Woodward website:

<http://www.woodward.com/pubs/current.pdf>

The revision level is shown at the bottom of the front cover after the publication number. The latest version of most publications is available at:

<http://www.woodward.com/publications>

If your publication is not there, please contact your customer service representative to get the latest copy.

Important definitions**WARNING**

Indicates a potentially hazardous situation that, if not avoided, could result in death or serious injury.

**CAUTION**

Indicates a potentially hazardous situation that, if not avoided, could result in damage to equipment.

**NOTE**

Provides other helpful information that does not fall under the warning or caution categories.

Woodward reserves the right to update any portion of this publication at any time. Information provided by Woodward is believed to be correct and reliable. However, Woodward assumes no responsibility unless otherwise expressly undertaken.

© Woodward
All Rights Reserved.

Revision History

Rev.	Date	Editor	Changes
A	2022-31-03	Ma	1.0-0 - Based on DTSC-200 V2.0017

Content

CHAPTER 1. GENERAL INFORMATION.....	5
Related Documents.....	5
QR Code.....	5
CHAPTER 2. APPLICATION MODES.....	6
Basic Applications.....	6
Application Mode: Util-Gen.....	6
Application Mode: Gen-Gen.....	7
Application Mode: Util-Util.....	8
Special Applications.....	9
Example Application: Transfer Delay (Util-Util).....	9
Example Application: External Permit Closed Transition.....	10
CHAPTER 3. APPLICATION WIRING.....	12
Wiring the Limit Switch Reply Inputs.....	12
Wiring "Closed" Replies Only.....	12
Wiring All Replies.....	13
CHAPTER 4. APPLICATION EXAMPLES.....	14
Gen-2-Gen Application.....	14
Functional Description.....	14
Description of the Gen-2-Gen Functions Depending on the Source Priority.....	15
CHAPTER 5. REALIZING SPECIAL FUNCTIONS.....	16
Enabling a Delayed Transition via Key Switch.....	16
External Initiation of an Extended Parallel Time.....	17
Opening an External CB with the Shunt Trip Enable Signal.....	18
Using the Overlap Time Counter.....	20

Illustrations And Tables

Illustrations

Figure 2-1: Application mode - Util-Gen.....	6
Figure 2-2: Application mode - Gen-Gen	7
Figure 2-3: Application mode - Util-Util	8
Figure 2-4: Example application - transfer delay (Util-Util)	9
Figure 2-5: Example application – external permit closed transition.....	10
Figure 2-6: Example application – LogicsManager	11
Figure 3-1: Limit switch reply wiring - "closed" replies only	12
Figure 3-2: Limit switch reply wiring - all replies.....	13
Figure 4-1: Gen-2-Gen application.....	14
Figure 5-1: Example - transition mode selection switch wiring	16
Figure 5-2: Example - <i>LogicsManager</i> Delayed mode active	16
Figure 5-3: Example - transition mode selection switch wiring	17
Figure 5-4: Example - <i>LogicsManager</i> Extended parallel time.....	17
Figure 5-5: Example - Shunt trip enable signal wiring	18
Figure 5-6: Example - <i>LogicsManager</i> Shunt trip enable signal.....	18
Figure 5-7: Overlap time counter screen	20

Tables

Table 1-1: Manual - Overview.....	5
-----------------------------------	---

Chapter 1. General Information

Related Documents



Type	English	German
DTSC-200A		
DTSC-200A - Installation	37939	-
DTSC-200A - Configuration	37940	-
DTSC-200A - Operation	37941	-
DTSC-200A - Application	this manual ⇨	-
DTSC-200A - Interfaces	37943	-

Table 1-1: Manual - Overview

Intended Use The unit must only be operated for the uses described in this manual. The prerequisite for a proper and safe operation of the product is correct transportation, storage, and installation as well as careful operation and maintenance.



NOTE

This manual has been developed for a unit fitted with all available options. Inputs/outputs, functions, configuration screens and other details described, which do not exist on your unit, may be ignored. The present manual has been prepared to enable the installation and commissioning of the unit. On account of the large variety of parameter settings, it is not possible to cover every possible combination. The manual is therefore only a guide. In case of incorrect entries or a total loss of functions, the default settings can be taken from the enclosed list of parameters at the rear of this manual.

QR Code



To get access to the complete product documentation, scan this QR code or use the following link:

→ <http://wwdmanuals.com/dtsc-200a>

Chapter 2. Application Modes

Basic Applications

Application Mode: Util-Gen

This application mode has the following characteristics:

- The ATS controller monitors a mains sources and a generator source and transfers the load to the generator source in case the mains source fails
- The ATS controller operates as Master controller

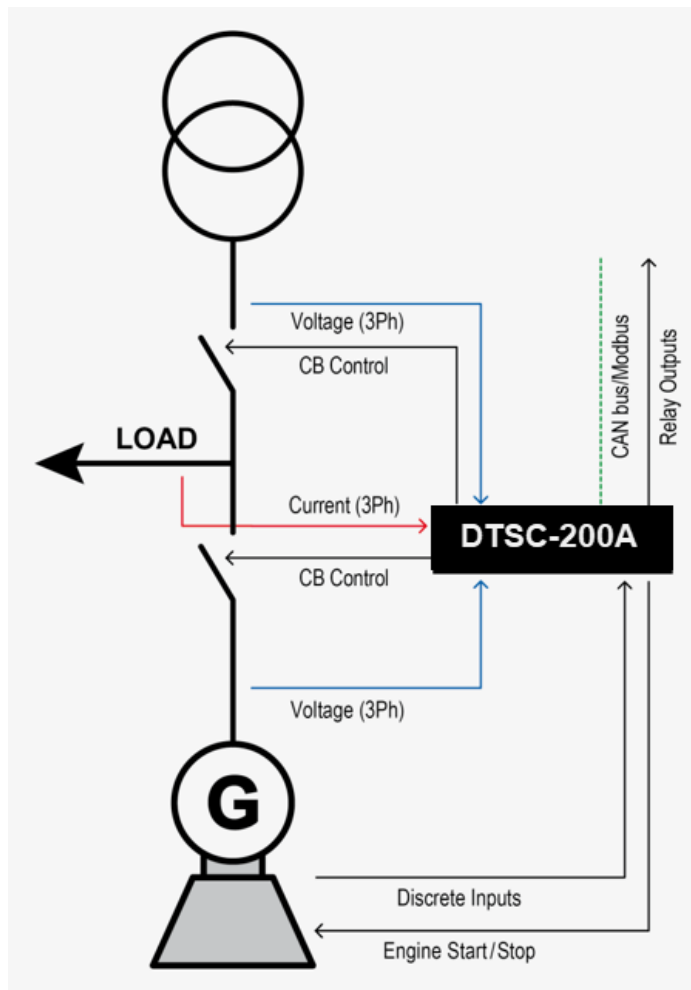

Figure 2-1: Application mode - Util-Gen

Application Mode: Gen-Gen

This application mode has the following characteristics:

- The ATS controller monitors two generator sources and transfers the load to the other source in case the regular source fails
- The ATS controller operates as Slave controller
- This application is not a stand-alone application and always combined with another ATS controller in Util-Gen application mode, which operates as Master controller

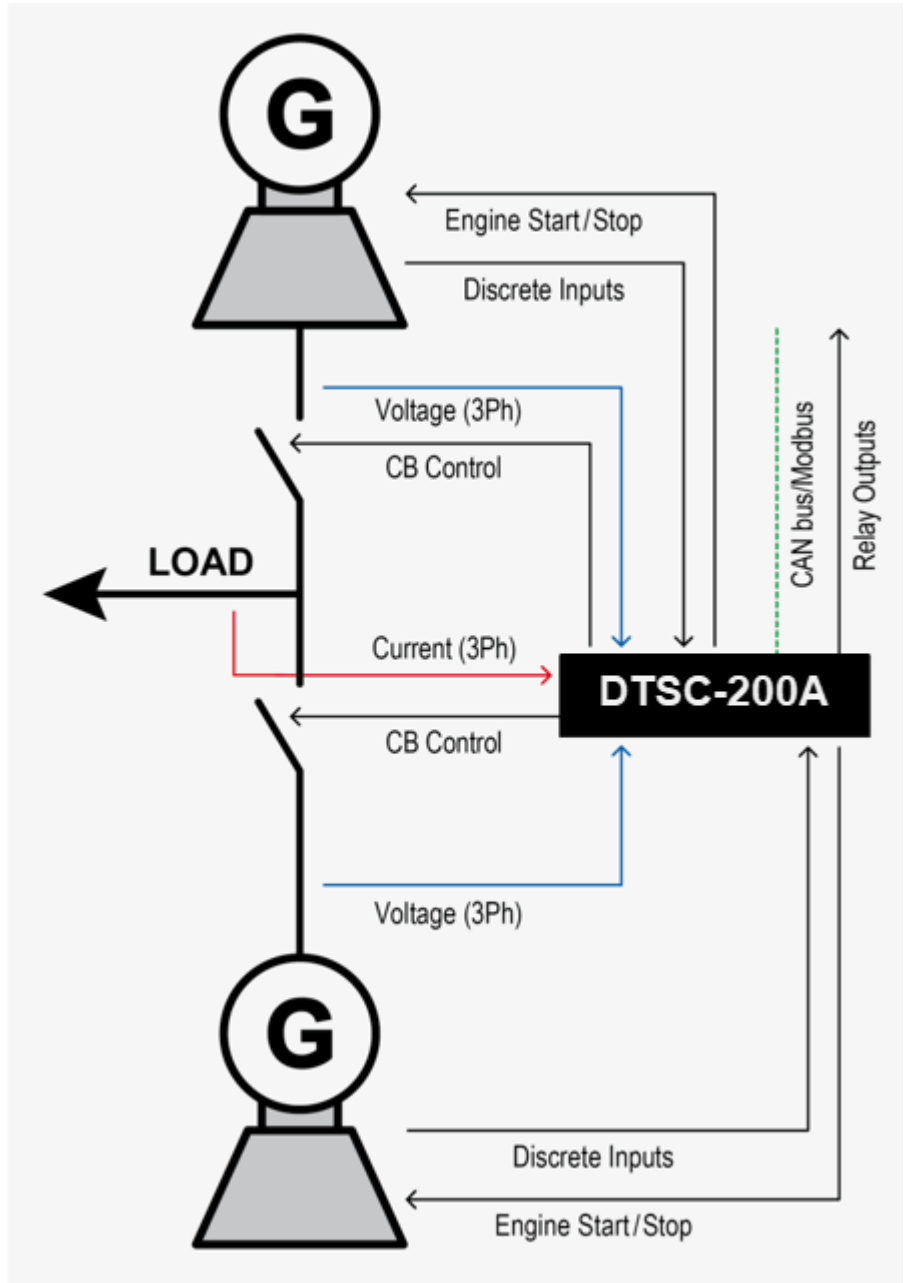

Figure 2-2: Application mode - Gen-Gen

Application Mode: Util-Util

This application mode has the following characteristics:

- The ATS controller monitors two mains sources and transfers the load to the secondary source in case the primary source fails
- The ATS controller operates as Master controller
- If “Connect to synchronous mains” parameter 8820 is enabled, the transfer between two utility sources is allowed for the phase angle being in the phase angle range from 0 to value of “Max. phase angle” parameter 8821.

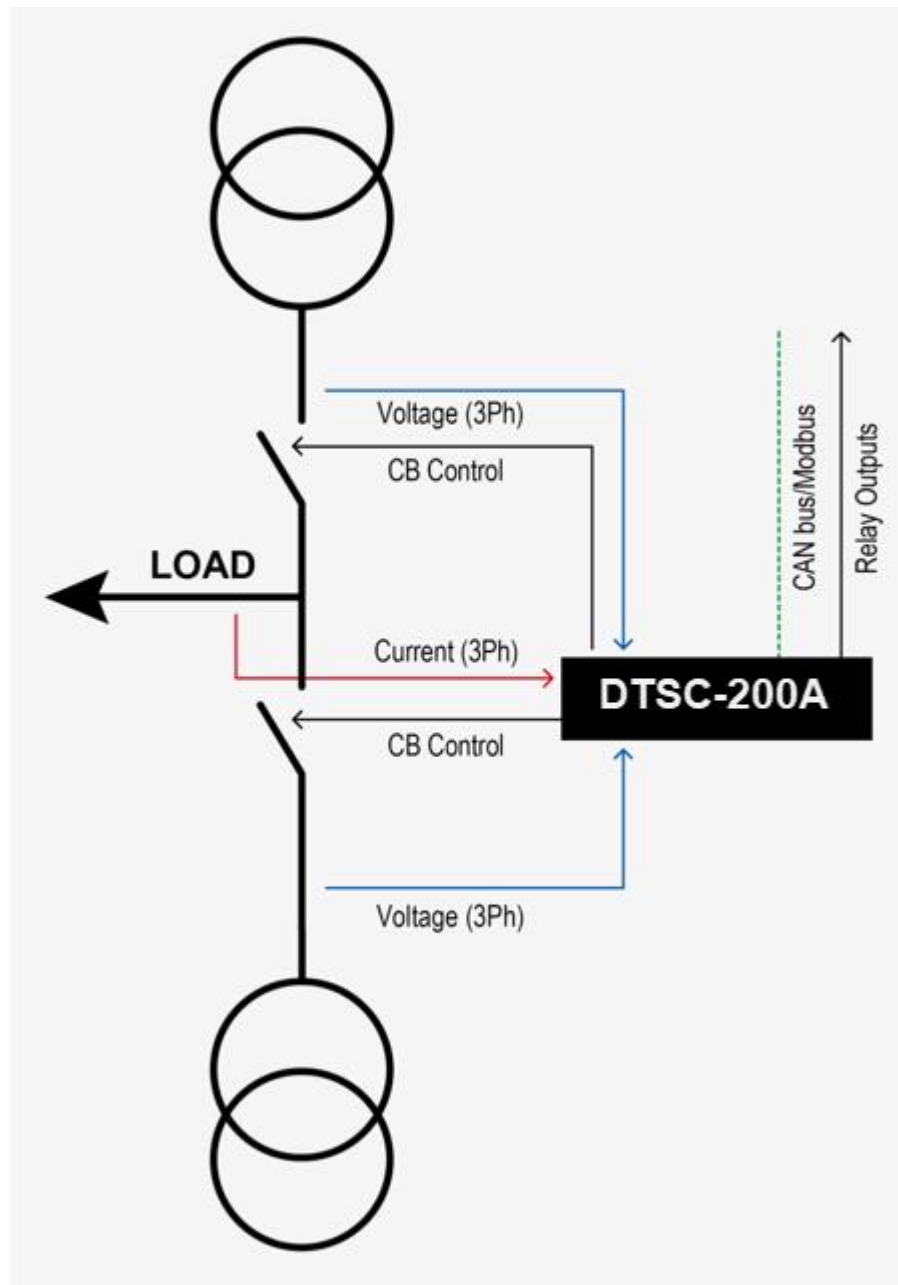

Figure 2-3: Application mode - Util-Util

Special Applications



Example Application: Transfer Delay (Util-Util)

The example shows two DTSC-200A (ATS 1 & ATS 2) which are feeding two loads (Load 1 & Load 2). Since the two mains sources are always present, all stable delay timers are always expired. In case “Source 1” would fail, both ATS would transfer both loads to “Source 2” immediately. In some transfer scenarios the loads can have different priorities. In a hospital for example, “Load 1” could be the “Emergency” load and “Load 2” a “Non-Emergency” load. In that case the system owner wants the “Emergency” loads to be transferred first, and “Non-Emergency” loads to be transferred second. In such a scenario the “Transfer delay timers” become an important tool to prioritize the loads. See the following example:

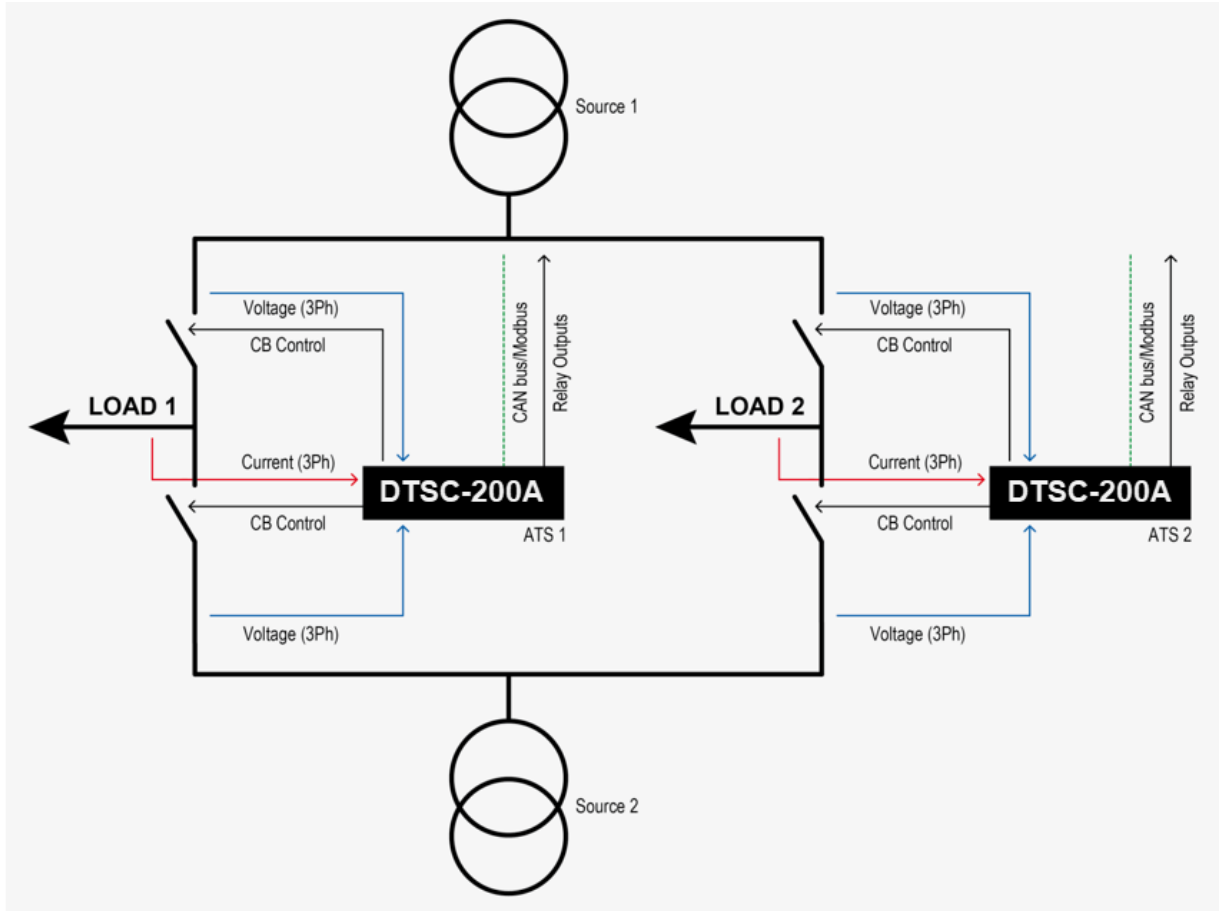

Figure 2-4: Example application - transfer delay (Util-Util)

Example details:

- Assumption: ATS 1 transfer delay timers are configured to 5 seconds
- Assumption: ATS 2 transfer delay timers are configured to 10 seconds
- Source 1 and Source 2 are available and OK
- Now Source 1 fails
- After the transfer delay timer of ATS 1 has expired (5 seconds), it will transfer Load 1 to Source 2
- After the transfer delay timer of ATS 2 has expired (10 seconds), it will transfer Load 2 to Source 2
- Conclusion: Without the transfer delay timers, both ATS would transfer the load to Source 2 simultaneously

Example Application: External Permit Closed Transition

In some ATS applications the customer may want to use an additional “Sync-check relay” in combination with the DTSC-200A for highest system security. Only if the external sync-check relay sends a “Synchronism detected” signal to the DTSC-200A, then the in-phase monitor in the DTSC-200A shall be activated.

The “Enable closed transition” LogicsManager is the ideal function to carry out this functionality.

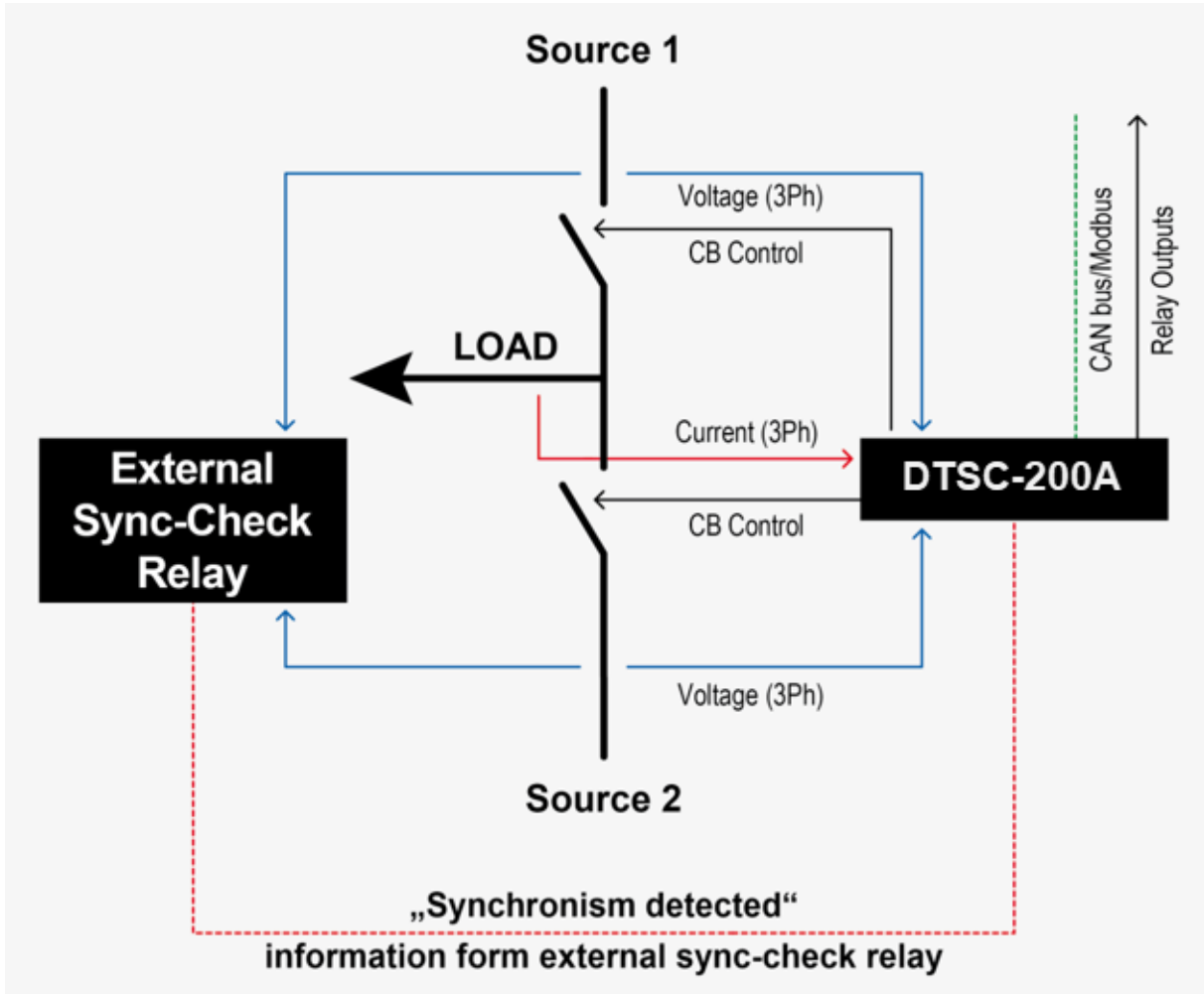

Figure 2-5: Example application – external permit closed transition

Setup:

- Parameter “Ext. permit for cld. trans.” must be set to “On” to activate this feature
- Parameter “Transfer switch type” must be configured to “Closed”
- Wire the relay output of the external sync-check relay to a free discrete input on the DTSC-200A
- Configure the LogicsManager for “Enable closed transition” in such a way, that the discrete input you intend to use is setup here

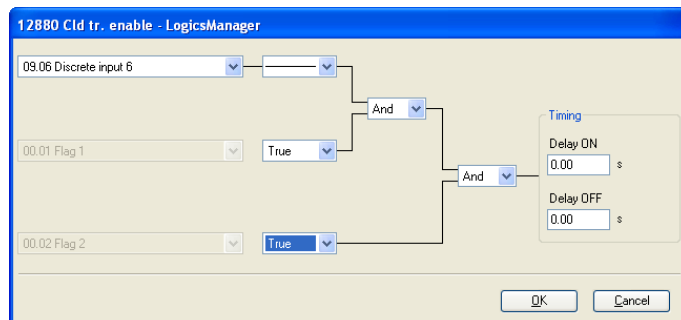

Figure 2-6: Example application – LogicsManager

Explanation LogicsManager:

- This LogicsManager becomes only active, if parameter “Ext. permit for cld. trans.” is set to “On”
- If discrete input “6” becomes active, the LogicsManager output will turn into a logical “TRUE” state, and activates the “In-Phase monitoring” of the DTSC-200A

Chapter 3. Application Wiring

Wiring the Limit Switch Reply Inputs



Wiring "Closed" Replies Only

i **NOTE** This wiring scheme must be used for Standard transition switches and Delayed or Closed transition switches if "Use Limit sw. OPEN replies" (parameter 3434) is configured to "NO".

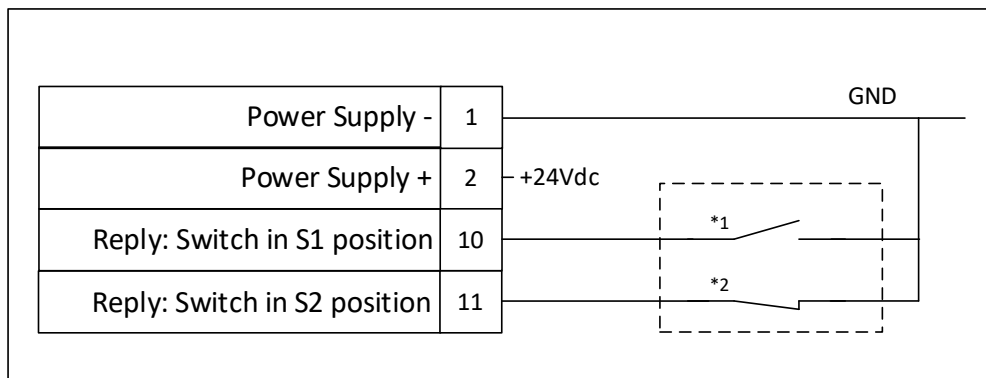

Figure 3-1: Limit switch reply wiring - "closed" replies only

- *1 Limit switch mounted on transfer switch indicating "S1 position"
- *2 Limit switch mounted on transfer switch indicating "S2 position"

i **NOTE**
Important:
If no voltage is applied to the reply DI, this DI is considered as active by the DTSC, i.e. the limit switch position is considered as "reached":

- Terminal 10 open = Switch is NOT in S1 position
- Terminal 10 with Power supply GND connected = Switch is in S1 position
- Terminal 11 open = Switch is NOT in S2 position
- Terminal 11 with Power supply GND connected = Switch is in S2 position

Wiring All Replies



NOTE

This wiring scheme must be used for Delayed or Closed transition switches if the Parameter "Use Limit sw. OPEN replies" is configured to "YES".

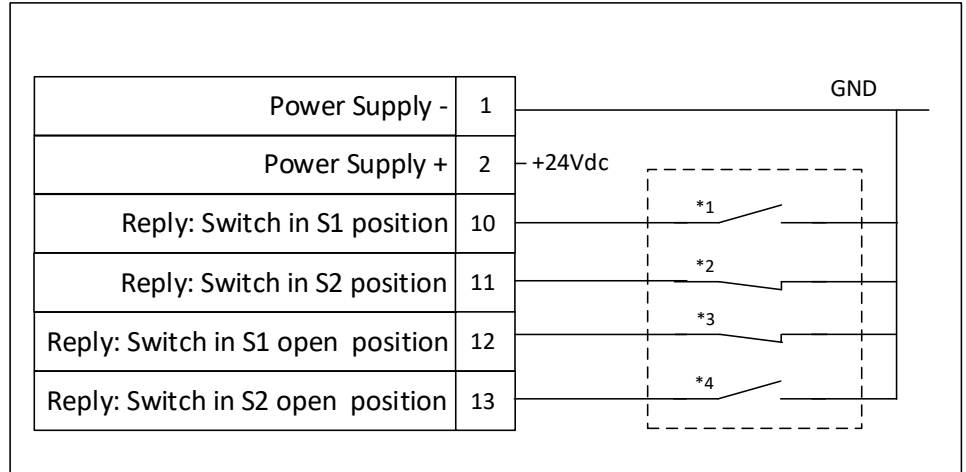

Figure 3-2: Limit switch reply wiring - all replies

- *1 Limit switch mounted on transfer switch indicating "S1 position"
- *2 Limit switch mounted on transfer switch indicating "S2 position"
- *3 Limit switch mounted on transfer switch indicating "S1 open position"
- *4 Limit switch mounted on transfer switch indicating "S2 open position"



NOTE

Important:

If no voltage is applied to the reply DI, this DI is considered as active by the DTSC, i.e. the limit switch position is considered as "reached":

Terminal 10 open = Switch is NOT in S1 position

Terminal 10 with Power supply GND connected = Switch is in S1 position

Terminal 11 open = Switch is NOT in S2 position

Terminal 11 with Power supply GND connected = Switch is in S2 position

Terminal 12 open = Switch is in S1 position

Terminal 12 with Power supply GND connected = Switch is NOT in S1 position

Terminal 13 open = Switch is in S2 position

Terminal 13 with Power supply GND connected = Switch is NOT in S2 position

Chapter 4. Application Examples

Gen-2-Gen Application



Functional Description

This application mode enables to perform an ATS application with two gensets. If the preferred genset fails, the second genset will be started automatically and the load will be transferred to the other genset (source).

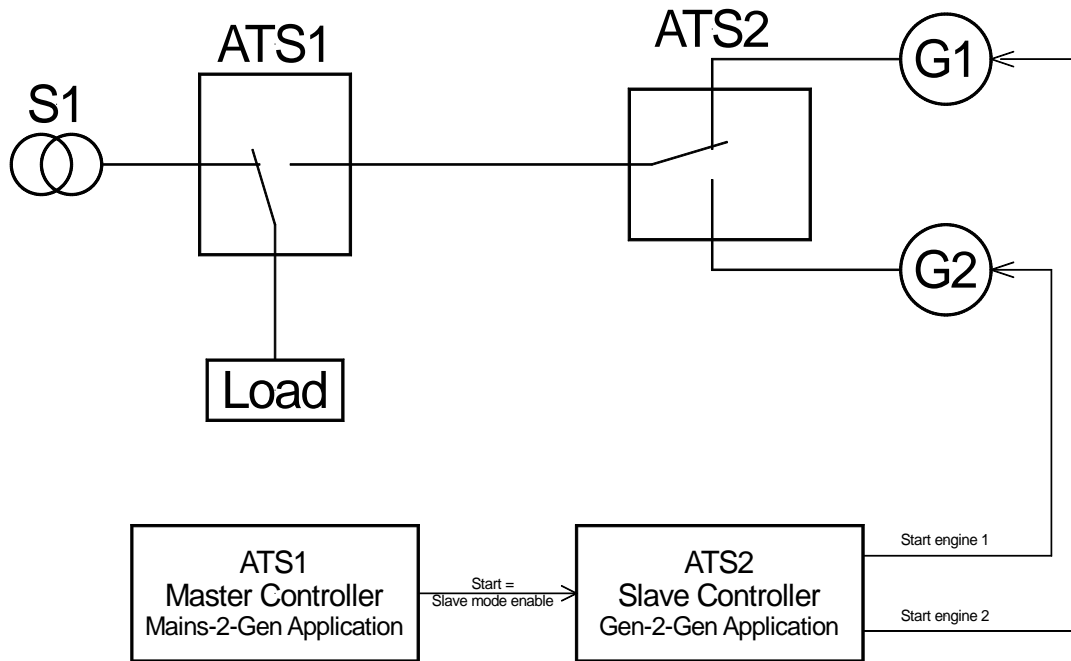

Figure 4-1: Gen-2-Gen application

Parameters Related with the Gen-2-Gen Application

- Source 1 Priority
- Source 2 Priority
- Application mode must be configured to "Gen-Gen"
- *LogicsManager* for "Gen-Gen enable" (must be enabled to start the preferred genset)
- *LogicsManager* flag "Engine 1 start" (must be configured to a relay to issue a second engine start signal for genset 1)
- "S1 start fail delay time"
- "S2 start fail delay time"
- "Preferred source delay time"
- "S1 outage delay"
- "S2 outage delay"
- "Engine 1 cooldown time"
- "Engine 2 cooldown time"

Configuration Checklist for Enabling the Gen-2-Gen Mode

Determine the source priority using the "Source 1 priority" and "Source 2 priority" parameters

Assign a discrete input to the "Gen-Gen enable" *LogicsManager* to release an engine start signal

A second engine start signal (*LogicsManager* Parameter 20.18 Engine 1 start) must be configured to a relay output

The "Cooldown timer" for both engines must be configured correctly

Description of the Gen-2-Gen Functions Depending on the Source Priority

Source 1 is Prioritized

If the "Gen-Gen enable" *LogicsManager* becomes "True", genset 1 will be started. This will be indicated on the display with the "Start engine 1" message.

If genset 1 starts before the configured "S1 start fail delay time" expires, the "Source 1 stable timer" will be started and the load will be transferred to genset 1.

Special case: genset 1 doesn't start

If genset 1 does NOT start within the configured "S1 start fail delay time", a "Start fail S1" failure will be issued, genset 2 will be started immediately and the load will be transferred to genset 2.

Source 2 is Prioritized

If the "Gen-Gen enable" *LogicsManager* becomes "True", genset 2 will be started. This will be indicated on the display with the "Start engine 2" message.

If genset 2 starts before the configured "S2 start fail delay time" expires, the "Source 2 stable timer" will be started and the load will be transferred to genset 2.

Special case: genset 2 doesn't start

If genset 2 does NOT start within the configured "S2 start fail delay time", a "Start fail S2" failure will be issued, genset 1 will be started immediately and the load will be transferred to genset 1.

Both Sources are NOT Prioritized (Priority = None)

If the "Gen-Gen enable" *LogicsManager* becomes "True", the gensets 1 and 2 will be started simultaneously. This will be indicated on the display with the "Start engines" message.

The first genset which starts becomes the "prioritized" source automatically. The engine start command for the other generator (secondary source) will be de-energized.

Now, the secondary source serves as emergency source in case that the prioritized source fails.

If genset 2 starts before the configured "S2 start fail delay time" expires, the "Source 2 stable timer" will be started and the load will be transferred to genset 2.

Special case: both gensets do not start

If genset 1 and genset 2 do NOT start within the configured "S1 Start fail delay time" or "S2 Start fail delay time", a "Start fail S1" and a "Start fail S2" failure will be issued. Both engine start signals will be disabled again. All failures must be acknowledged before a new start attempt may be performed.

Chapter 5. Realizing Special Functions

Enabling a Delayed Transition via Key Switch



Sometimes it may be necessary to install a key switch for selecting the transition mode. This may happen if the utility provider prevents a "parallel operation" i.e. an operation with a closed transition switch.

In this case it is possible to install a key switch, which is wired to a discrete input (in this example DI 6) of the DTSC, in the front panel.

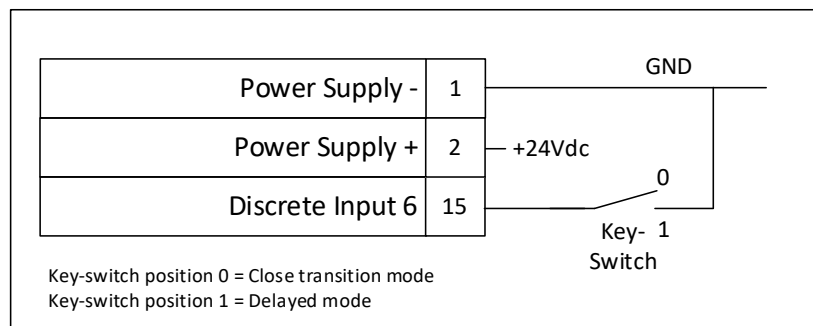

Figure 5-1: Example - transition mode selection switch wiring

The *LogicsManager* function "Delayed mode active" must be configured to this discrete input to become TRUE as soon as this DI is energized (key switch is turned to "Delayed").

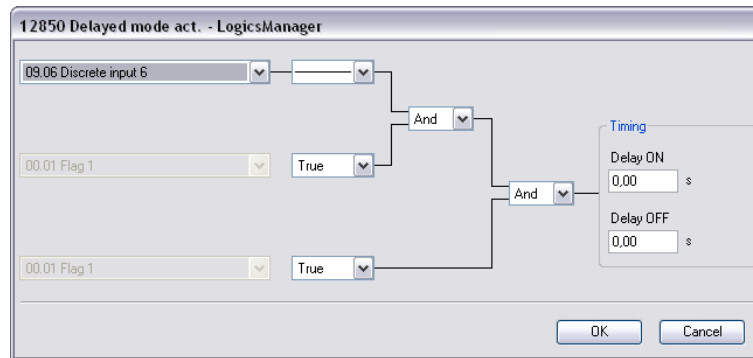

Figure 5-2: Example - *LogicsManager* Delayed mode active

NOTE
Please refer to parameter "In-phase check for DLY trans." (parameter 4585) in the configuration manual (37940).

External Initiation of an Extended Parallel Time



If a closed transition is performed, the overlap time of the make-before-break process, in which both sources are parallel, is less than 100 ms (refer to parameter 4577). If this time is to be extended, a *LogicsManager* function is available to keep the transition switch in overlap position. This may be achieved by a digital signal of an external synchronization device for example.

In this case it is possible to configure the external synchronization device to close a relay, which is wired to a discrete input (in this example DI 7) of the DTSC, as long as the transfer switch shall remain in parallel position.

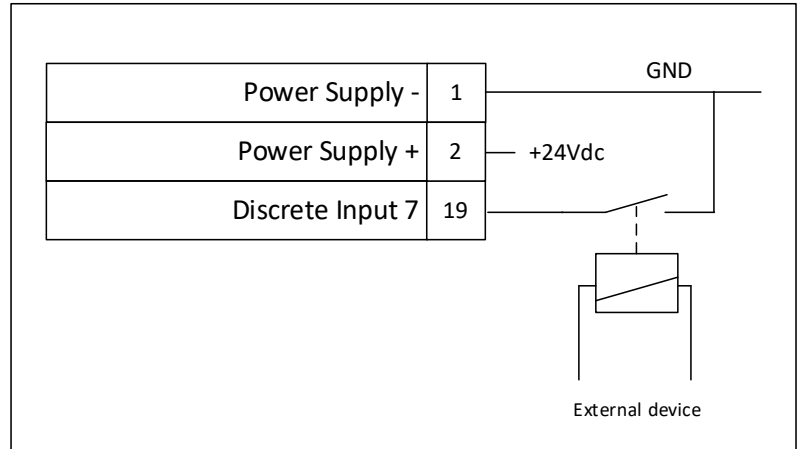

Figure 5-3: Example - transition mode selection switch wiring

The *LogicsManager* function "Extended parallel time" must be configured to this discrete input to become TRUE as soon as this DI is energized (external synchronization device energizes its relay to keep the transfer switch in parallel position).

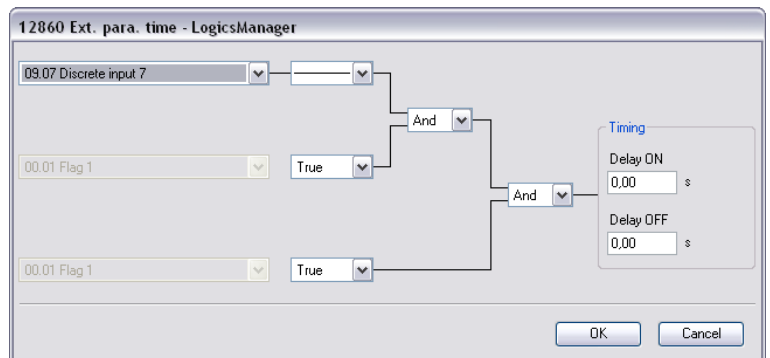

Figure 5-4: Example - *LogicsManager* Extended parallel time

Opening an External CB with the Shunt Trip Enable Signal



If a closed transition transfer switch fails to open from overlap position due to a mechanical or electrical failure, it is necessary to provide an external circuit breaker to disconnect the source from the load to prevent a continuous parallel time. The DTSC-200A provides a shunt trip enable signal, which is enabled if the unit fails to open the transfer switch from both sources.

In this case it is possible to configure a discrete output of the DTSC-200A (in this example R 3) to energize when the shunt trip signal is enabled using the *LogicsManager*. The discrete output will then open an external circuit breaker to disconnect the source from the load.

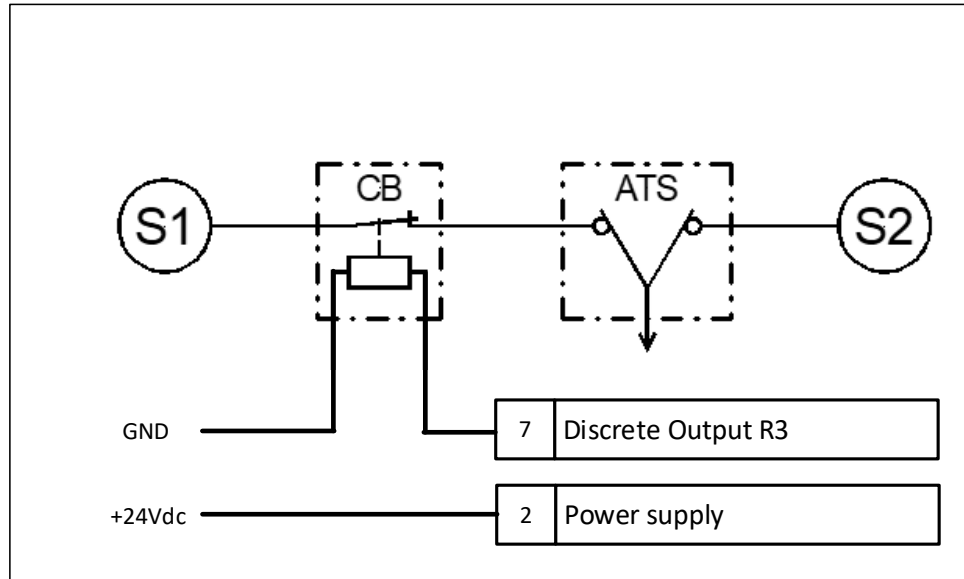

Figure 5-5: Example - Shunt trip enable signal wiring

Please configure *LogicsManager* function "Relay 3" with command variable "Shunt trip enable signal (20.12)" as shown in Figure 5-6.

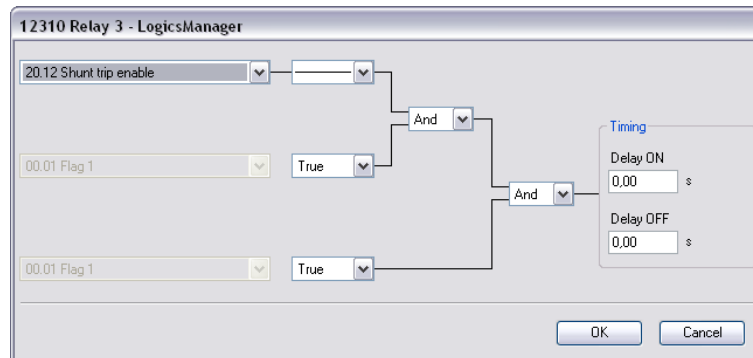
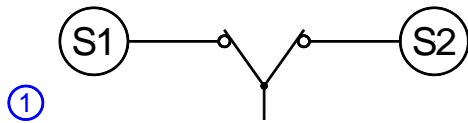

Figure 5-6: Example - *LogicsManager* Shunt trip enable signal

The following example shows a transfer sequence, which fails to open the switch from both sources, which causes the shunt trip enable flag to be enabled:



Initial situation:

A transfer from source 1 is initiated and the transfer switch is in overlap position.

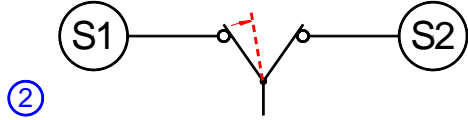

If the maximum overlap time has expired and the *LogicsManager* function "Extended parallel time" is FALSE, the unit tries to open the transfer switch from the previous source. If this fails, the unit detects an opening failure from the previous source.

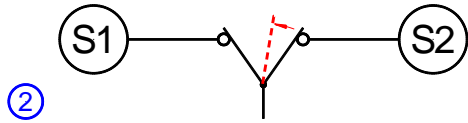

Now, the unit tries to open the transfer switch from the new source. If this fails as well, the unit detects an opening failure from the new source and enables the shunt trip enable flag (20.12). This flag remains enabled until the switch is opened and the failure has been acknowledged.

Using the Overlap Time Counter



The DTSC-200A provides an overlap time counter, which displays the transfer switch overlap time of the last transfer. This counter will be refreshed with every transfer across the overlap position. The overlap time counter is displayed on the Counter screen, which may be viewed by pressing next page button until the Counter screen is displayed.

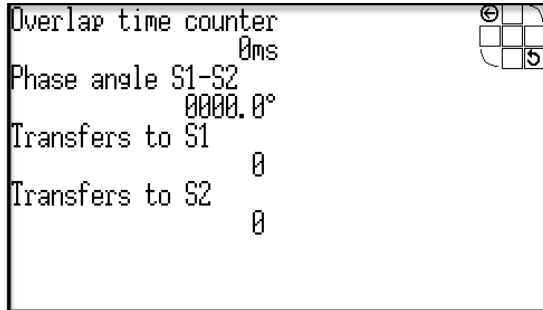

Figure 5-7: Overlap time counter screen

It is very important for some applications that a maximum overlap time is not exceeded. Aging or wear of the transfer switch as well as heavily chattering feedback contacts of the limit switches may result a deterioration of the transfer characteristics of a switch, which again increases the overlap time. The overlap time counter provides a convenient way to monitor the time for which the transfer switch has remained in overlap position for the last transfer.



NOTE

Overlap time measurement has an intense dependency on the quality of the feedback signals. If the feedback signals are chattering heavily, deviations of the time measurement may occur. If the feedback signals do not chatter, the accuracy of the overlap time counter is +1 ms. Tests with a heavily chattering signal with a chatter time of approx. 20 ms have shown a deviation of approx. +3 ms. This means that the actual overlap time may be shorter than the reading.

This feature is intended to estimate whether a transfer switch is still operated within its specifications. If overlap times outside the specifications are detected using the DTSC-200A, the overlap time of the transfer switch should be determined using professional calibrated test tools like oscilloscopes for example.

We appreciate your comments about the content of our publications.
Please send comments to: stgt-documentation@woodward.com
Please include the manual number from the front cover of this publication.



Woodward GmbH
Handwerkstrasse 29 - 70565 Stuttgart - Germany
Phone +49 (0) 711-789 54-510 • Fax +49 (0) 711-789 54-101
stgt-info@woodward.com

Homepage

<http://www.woodward.com/power>

Woodward has company-owned plants, subsidiaries, and branches, as well as authorized distributors and other authorized service and sales facilities throughout the world.

Complete address/phone/fax/e-mail information for all locations is available on our website (www.woodward.com).

2022/04/Stuttgart